



ASIA

Delta Electronics, Inc.

Taoyuan1

31-1, Xingbang Road, Guishan Industrial Zone,
Taoyuan County 33370, Taiwan, R.O.C.
TEL: 886-3-362-6301 / FAX: 886-3-362-7267

Delta Electronics (Jiang Su) Ltd.

Wujiang Plant3

1688 Jiangxing East Road,
Wujiang Economy Development Zone,
Wujiang City, Jiang Su Province,
People's Republic of China (Post code: 215200)
TEL: 86-512-6340-3008 / FAX: 86-769-6340-7290

Delta Electronics (Japan), Inc.

Tokyo Office

Delta Shibadaimon Building, 2-1-14 Shibadaimon,
Minato-Ku, Tokyo, 105-0012, Japan
TEL: 81-3-5733-1111 / FAX: 81-3-5733-1211

Delta Electronics (Korea), Inc.

Donghwa B/D 3F, 235-6, Nonhyun-dong,
Kangnam-gu, Seoul 135-010, Korea
TEL: 82-2-515-5303/5 / FAX: 82-2-515-5302

Delta Electronics (Singapore) Pte. Ltd.

8 Kaki Bukit Road 2, #04-18 Ruby Warehouse Complex,
Singapore 417841
TEL: 65-6747-5155 / FAX: 65-6744-9228

Delta Energy Systems (India) Pvt. Ltd.

Plot No. 27 & 31, Sector-34, EHTP,
Gurgaon-122001 Haryana, India
TEL: 91-124-4169040 / FAX: 91-124-4036045

AMERICA

Delta Products Corporation (USA)

Raleigh Office

P.O. Box 12173, 5101 Davis Drive,
Research Triangle Park, NC 27709, U.S.A.
TEL: 1-919-767-3813 / FAX: 1-919-767-3969

EUROPE

Deltronics (The Netherlands) B.V.

Eindhoven Office

De Witbogt 15, 5652 AG Eindhoven, The Netherlands
TEL: 31-40-2592850 / FAX: 31-40-2592851

*We reserve the right to change the information in this catalogue without prior notice.



DOP/TP

DELTA Human Machine Interface



www.delta.com.tw/industrialautomation



Various dimensions, display size and performance for a wide range of industrial applications

Performance

TP Series

TP08
Monochrome STN
Display max. 8 lines text

TP05
Monochrome STN
Display max. 5 lines text

TP04
Monochrome STN
Display max. 4 lines text

TP02
Monochrome STN
Display max. 2 lines text

3.8"Series

AS38
8 Shades of Blue STN
USB HOST

5.7"Series

AE57
8 Shades of Blue STN Extension Interface SM Card
16 Shades of Gray FSTN Extension Interface SM Card
256 Colors STN Extension Interface SM Card

AS57
8 Shades of Blue STN USB HOST
256 Colors STN USB HOST

8"Series

AE80
65536 Colors TFT
USB HOST
Extension Interface
SM Card

A80
65536 Colors TFT
USB HOST

9.4"Series

AE94
8 Shades of Blue STN
USB HOST
Extension Interface

10.4"Series

AE10
65536 Colors TFT
USB HOST
Extension Interface

A10
65536 Colors TFT
USB HOST

Dimensions

Series	TP02	TP04	TP05	TP08	AS		
Display Size	72*22mm	3"(67*32mm)	3.6"(83*41mm)	3.6"(83*41mm)	3.8"	5.7"	5.7"
Resolution	160*32	128*64	160*80	240*128	320*240	320*240	320*240
Display Color	Monochrome	Monochrome	Monochrome	Monochrome	8 Shades of Blue	8 Shades of Blue	256 Colors
Flash Memory	256K		1M	1M	1M	1M	1M
SRAM	32K		64K		128K	128K	128K
Function Key	16	12	24	24	4+SYS	4+SYS	4+SYS
USB HOST	N/A	N/A	N/A	N/A	YES	YES	YES
SM Card	N/A	N/A	N/A	N/A	N/A	N/A	N/A
Extension Module	N/A	N/A	N/A	N/A	N/A	N/A	N/A
Serial Communication	COM * 2	COM * 2	COM * 2	COM * 2	COM * 3	COM * 3	COM * 3
Editing Software	TPEditor				Screen Editor		

A			AE			
5.7"	8"	10.4"	5.7"	8"	9.4"	10.4"
320*240	640*480	640*480	320*240	640*480	640*480	640*480
8 Shades of Blue 16 Shades of Gray 256 Colors	65536 Colors	65536 Colors	8 Shades of Blue 16 Shades of Gray 256 Colors	65536 Colors	8 Shades of Blue	65536 Colors
3M	7M	7M	3M	7M	7M	7M
256K	512K	512K	512K	512K	512K	512K
4+SYS	6+SYS	7+SYS	4+SYS	6+SYS	11+SYS	7+SYS
N/A	YES	YES	N/A	YES	YES	YES
YES	N/A	N/A	YES	YES	N/A	N/A
N/A	N/A	N/A	YES	YES	YES	YES
COM * 2	COM * 3	COM * 3	COM * 3	COM * 3	COM * 3	COM * 3
			Screen Editor			

Features of HMI

Extension Module

Offer various kinds of optional extension modules to extend the HMI functionality.

Extension Printer Module:
Used to connect to printer.

Extension DIO Module:
Match the need for display, control and operation all-in-one application.

Extension Ethernet Module:
Peripheral equipment can be connected by Ethernet Module. The ability to long-distance data transmission enables fast and effective monitoring and controlling.

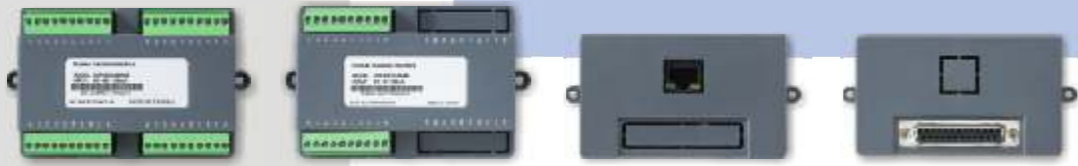

Display

Full-color Display:
Offer many different displays for the users to produce colorful, bright and high-resolution images. Max. 65536 colors TFT LCD display is provided. Clear and realistic images and graphs can be easily created.

Transferring Data

Rapid USB Download:
Efficiently reduce download time by using USB high-speed transmission interface.

USB Flash Drive for Copying Screen Data:
USB flash drive is used to copy the HMI screen data. It also provides password protection and can limit the frequency of copying the screen data. Using USB flash drive can protect screen data effectively and achieve easier maintenance of remote equipment.



Printer

HMI can be connected to different kinds of inkjet printers and dot matrix printers by using USB Host or Extension Printer Module.

- Connectable Printers:
- EPSON Stylus C45
 - EPSON Stylus C65
 - EPSON Stylus C67
 - EPSON Stylus Photo
 - HP LASERJET 1022N
 - HP DESKJET 400
 - MP_A16
 - MP_A40
 - EPSON LX-300+
 - Panasonic KX-P1150
 - ZEBRA TLP2844



Fast Operation

PLC program can be upgraded and maintained via HMI. It provides fast operation with less wiring and less connections.

Communication

Serial Communication Interface:
Support up to three COM ports for serial communication. It can connect to multiple controllers in serial simultaneously. Besides Delta industrial automation products, Delta HMI product can also support more than twenty well-known brands of controllers and continue to increase.



Saving Data

Screen data, history records and recipes can be easily saved through SM card or USB flash drive.

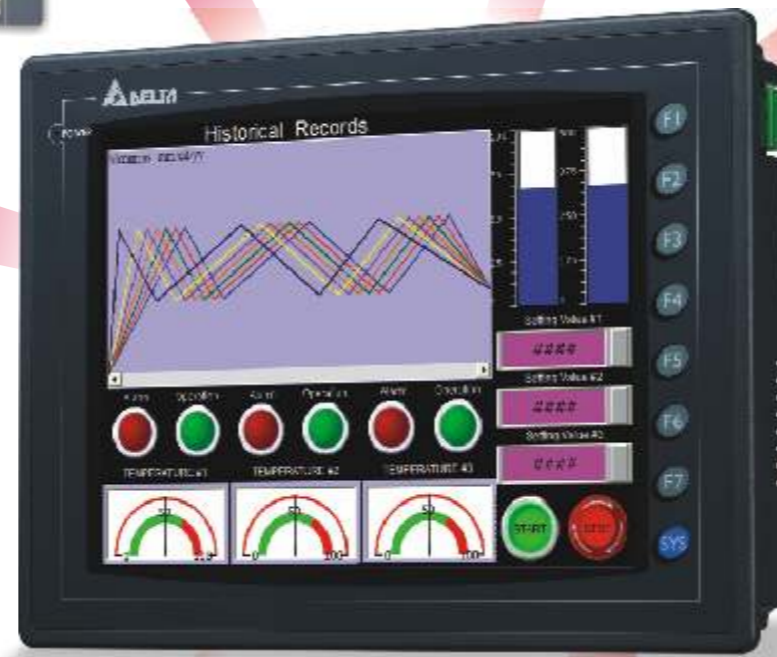

HMI Software Editor - Screen Editor

Easy-to-understand Toolbar:
Easily execute any editing operation by using the icons on Toolbar.



Element Toolbar:
Various elements satisfy the needs of all applications.



Work Place (Drawing Area):
The users can create and edit all elements here.
The work place will change to different size automatically depending on selected HMI model.

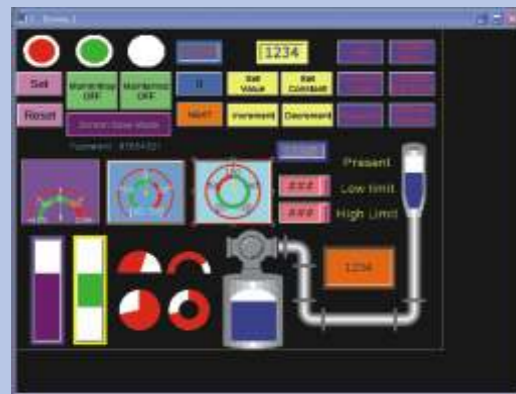

Layout Toolbar:
It helps the users to align, position the element and also allows the users to make the element be the same size.

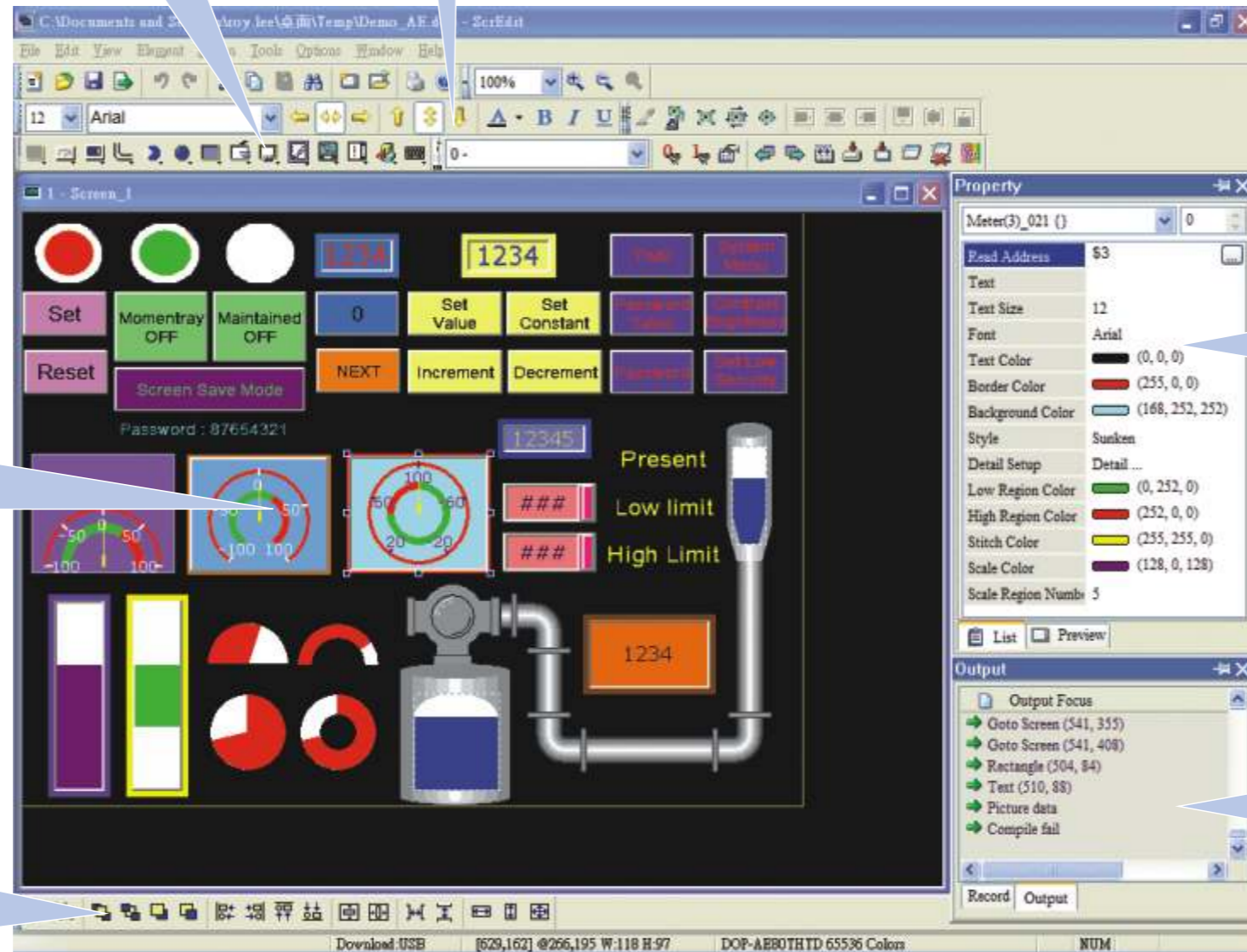
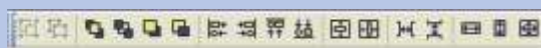

Property Table:
It provides element property settings for each element.



Output Window:
All editing actions and output messages will be shown here when compile is finished.



Recommended System Requirements of Screen Editor:

Item	System Requirement
CPU	Pentium III 500MH or higher
Memory	256 MB or more of available space is needed.
Hard Disk	400 MB or more of available space is needed.
Display	Display resolution of 800 x 600 or more is recommended.
Printer	Printer that is compatible with Windows 2000/WindowsXP
OS	Windows 2000/WindowsXP

The users can download the Screen Editor, the program editor of Delta HMI product and the user manual via the following link: <http://www.delta.com.tw/industrialautomation/>.

Screen Editor Software Features

Multi-Language Interface

3 viewable languages are provided: Traditional Chinese, Simplified Chinese and English. More languages support, such as Korean, Turkish, etc. will be available soon.



Flexible Recipe Function. 32-bit recipe is supported.

Simple recipe editing function can save parameter values to HMI and command the controller to change the parameters. This is convenient for different production process change. Support 32-bit floating point format for high-precision production process. The recipes can be saved to SM Card or USB flash drive. Besides, CSV file data is allowed and can also be edited.

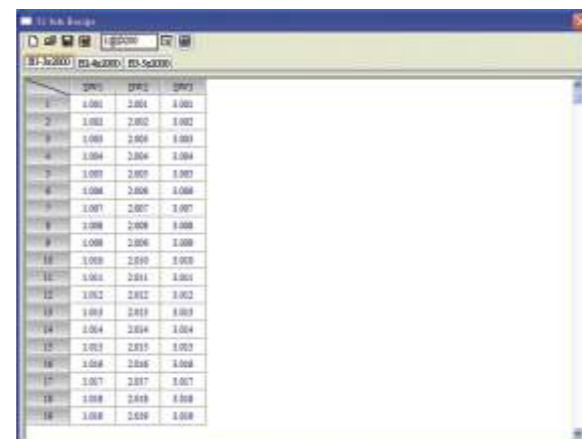

Convenient Screen Management

Use HMI screen management function can easily manage the designed screen.

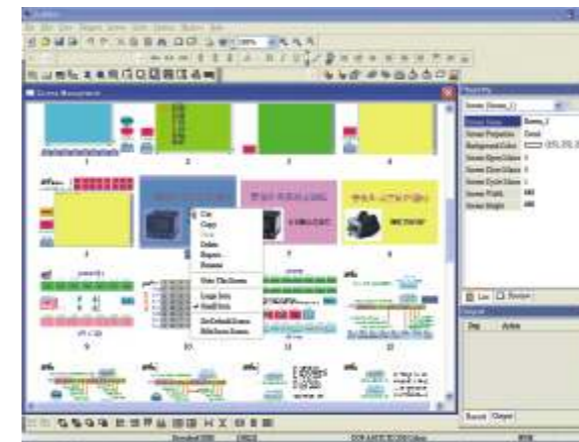

Multi-Screen Editing

Screen Editor allows the users to edit several projects at the same time. The users can work on different screens and copy the images or data from one project to another.

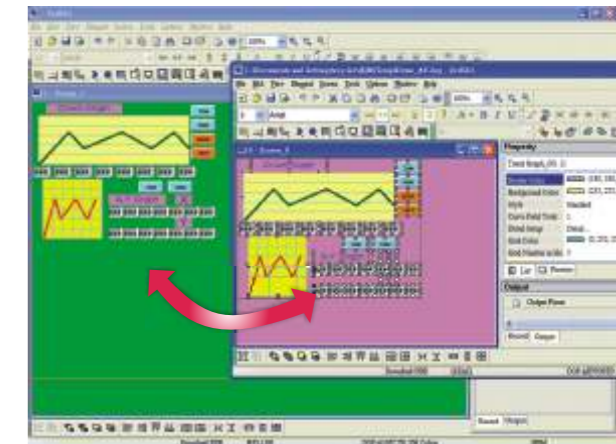

Picture Bank

The users can use this option to import various pictures (*.bmp, *.gif, *.jpg, *.ico) to enrich the screen selection and make the Picture Bank more plentiful. The picture can be converted to different color according to different types of models.



Screen Editor Software Features

Easy Debugging

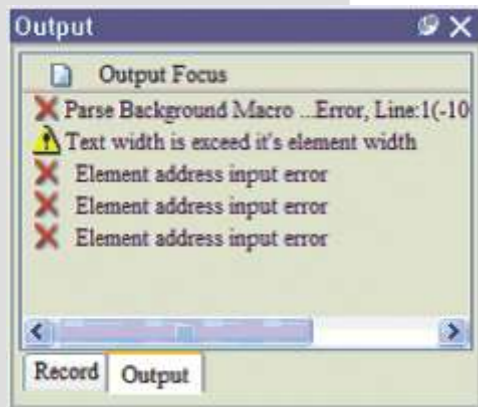

Once an error occurs when compile is finished, the error message will display in Output Window. Then, the users can know where the error occurs and proceed debugging immediately

The users also can perform debugging without HMI. To save the design time, the on-line / off-line simulation function can be easily executed by using just PC software.

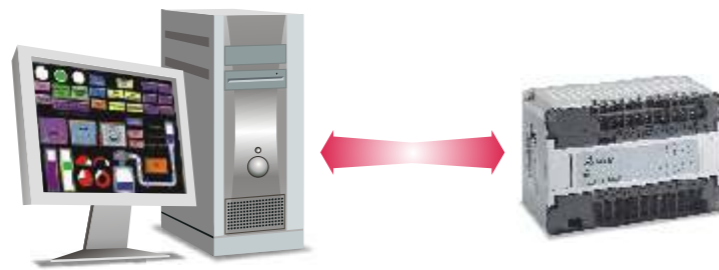

Multilingual Display



Max. 8 user-defined languages can be displayed on HMI screen by simple software editing. It is easy for the users to switch the desired language and let your equipment keep track with the international standard.

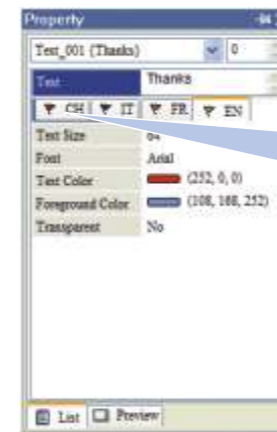

Chose different tab to switch to different language.

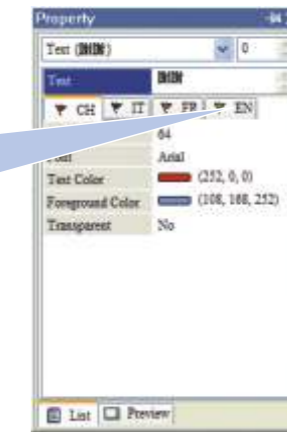

Macro Editing Function

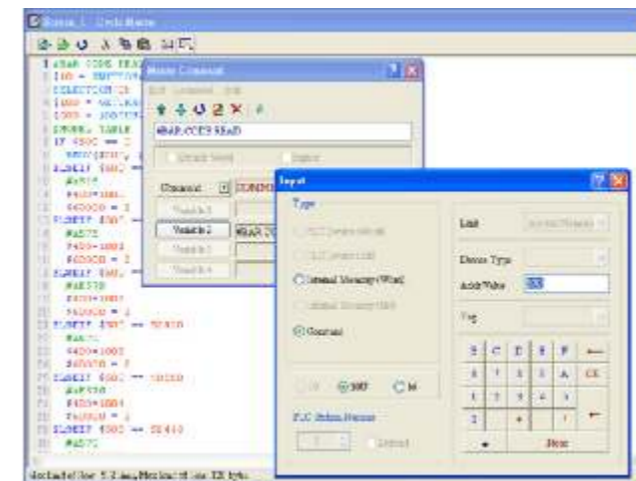

Powerful macro commands provide four fundamental operations of arithmetic, condition judgments, data move and the operation of floating points. Using macro editing function can reduce the PLC program editing efficiently. Easy-to-learn interface provides good flexibility in use and lets the users have more selection for program editing. Communication macro commands are also provided and the users can transmit and receive data through COM port to control the special equipment.

User Security Level

Provide 8 security levels with password protection for the authorization control for different elements.

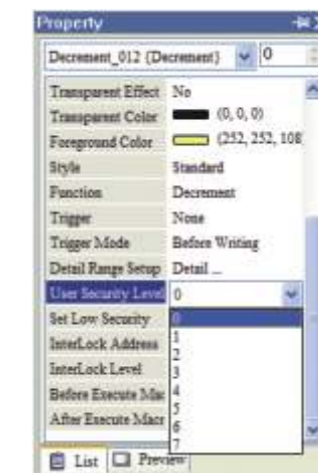

Other Features

Four kinds of controllers can be connected simultaneously (DOP-AE series only)

DOP-AE series supports up to 3 COM ports for serial communication. In addition to COM ports, if the users also connect extension Ethernet module, then DOP-AE series can connect to four kinds of external controllers at the same time. An ultimate central control system for factory control is completed.

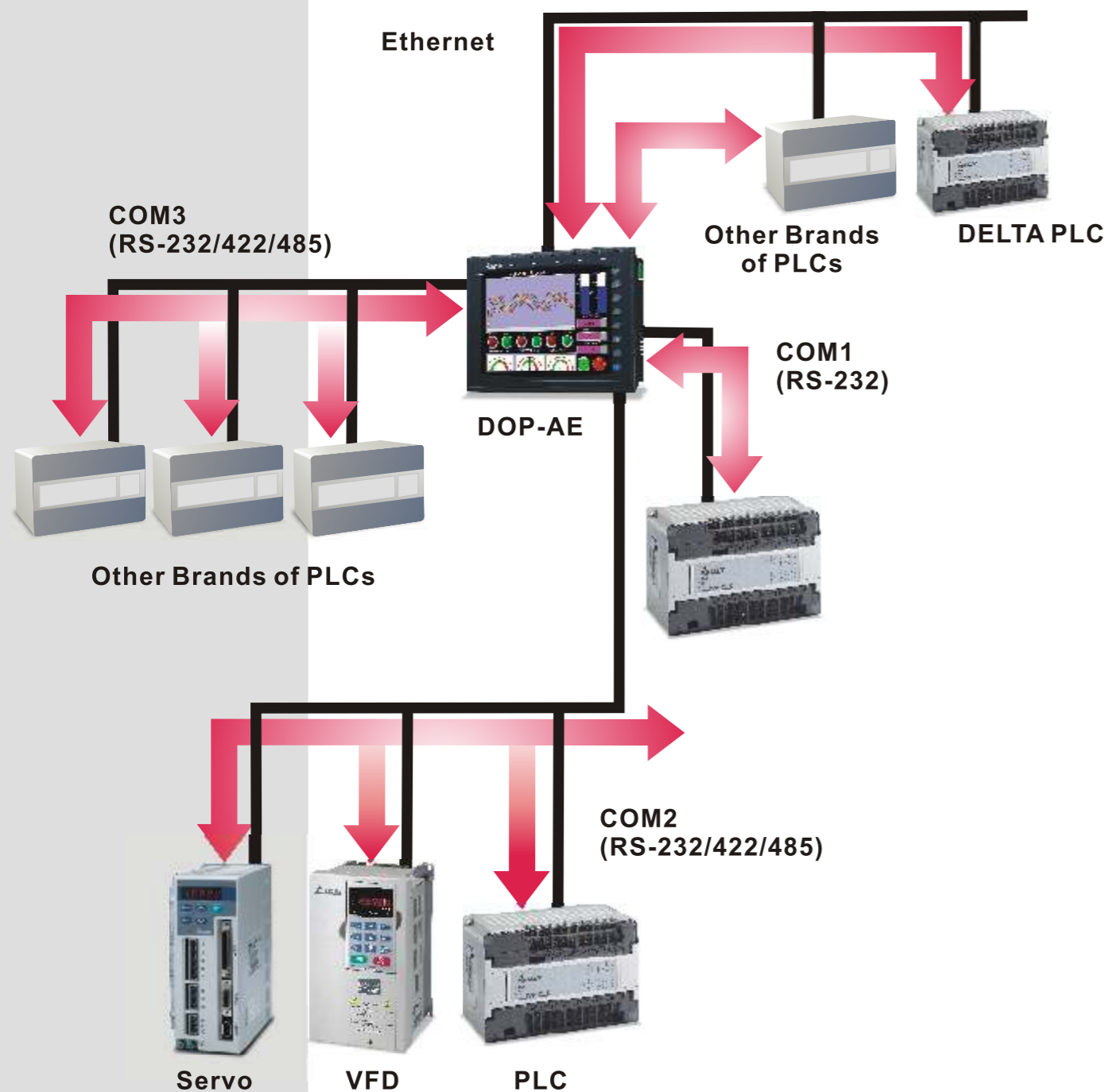

Optional Extension Module

AE series HMI product can connect to various kinds of optional extension modules to extend the HMI functionality through the extension interface located on rear cover.



Extension DIO Module:
Working Extension DIO Module with HMI-WPLSoft built in, Screen Editor can complete HMI to be an all-in-one, cost-effective controller with excellent control performance for display, control and operation.

Editing PLC programs by using HMI-WPLSoft



Screen Editor Editing Screen

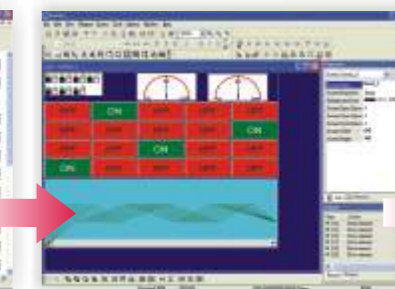

Easily achieve all-in-one requirement for display, control and operation

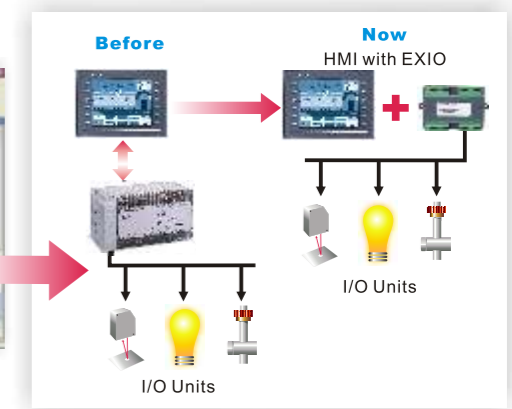

Extension Printer Module:

When USB Host is connected to USB flash drive, the users can use this module and connect to a printer.



Extension Ethernet Module:

Using Extension Ethernet Module can connect peripheral equipment and create the network of HMI and peripheral equipment. The transmission distance will be no longer limited. It supports Modbus communication on TCP/IP and will increase other compatible communication protocol for Ethernet soon.



TP Features

TPEditor Software Features

Backlight ON/OFF Control via Software

Backlight ON/OFF control via software
Screen Auto-Change Function:
ON/OFF status of backlight and screen
auto-change function could be controlled by
the settings of parameters set in TPEditor software.

TP05G-BT2 TP08G-BT2
5 Lines Display for TP05 8 Lines Display for TP08
160 x 80 pixels 240 x 128 pixels



Function Keys (User-defined):
F1-F5 New functions are: Recipe Write/Read,
Screen Scroll function

Product Performance

Feature 1. Screen Scroll Function
This function can divide screen into 2 parts
and the users can use function key to scroll the
screen



Extension Port for Program Copy Card
(TP-PCC01):
TP series provides optional Program
Copy Card (TP-PCC01) to copy
user program. The users can easily
read and write data and program
from TP series without using
TPEditor Software rapidly.



RS-232/422/485
Two serial COM ports for flexible and wide
applications

Feature 2. Recipe function / User interface
Provide the same recipe function as HMI to
enhance application performance of TP series.

Feature 3. Large Displaying Screen
Offer the best viewing experience and
operation environment. Max. 8 lines of text
can be displayed.

Feature 4. New Macro Command
Support new macro commands in common
use, such as process control, arithmetic
operation, bit settings and data move, etc.
macro commands.

Software Editor--TPEditor

TPEditor provides Windows fonts for editing
and page program self-debug. It has numerous
functions, including button, numeric input /
display, meter, lamp, messages display with
both text and graphs and it supports multiple
brands of controllers.

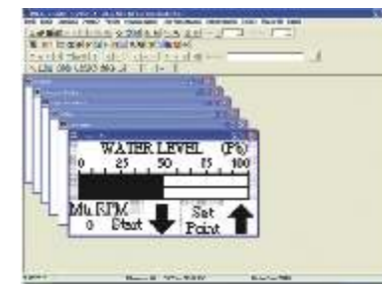

Page Change Control

Page can be set as invisible. The users can
change page by different conditional controls.



Real Time Clock

It's built-in real time clock (Not for TP02G). It
can transfer time data to the PLC that doesn't
have real time clock function to have time
control function.

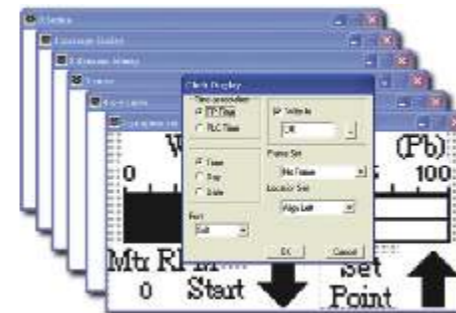

Communication

COM1 and COM2 can be used for the same
communication protocol with different format
controllers to construct single or multiple-drop
link.

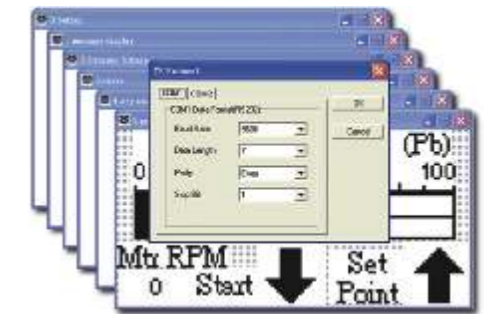

Page Management

It is convenient for the users to preview page
quickly and execute add, delete and insert
functions for page.



User Security Level

It provides 5 security levels with password
protection and 10 sets of user passwords for
flexible handling.

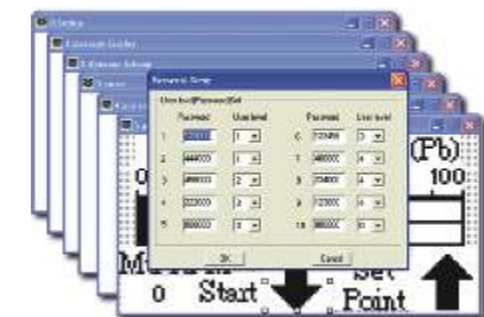



TPEditor Software Features

HMI Specifications

Property Table Setting

For better and faster settings, a detachable property table is provided for the user to view and edit in TP more efficiently. The users can choose traditional method of editing the programs and objects or use property table to work in TP.

Property	
<input type="checkbox"/> Basic Info	{Left,Top,Width,He
Write Device Add	D0
HMI Port	COM1
Unit Addr	1
Read Setting	No
Call Setting	No
Function Key Set	No
User Level	0
Frame Setting	No Frame
Font Setting	5x8
Hori. Alignment	Middle
Vert. Alignment	Middle
Value Type	Unsigned
Value Length	16 Bits
Integer Number	5
Decimal Number	0
Max Value	65535
Min Value	0

Operator Keys

Numeric & Other Function Keys (User-defined)
 Numeric Keys: 0-9, decimal point, +/-
 Movement Keys : Up and Down
 Other Function Keys: Backspace, Shift, Clear (CLR), Enter (ENT) Including F1-F5, total 23 convenient user-defined function keys provided for operation.

System-defined Keys: ESC. It is not user-defined function key.

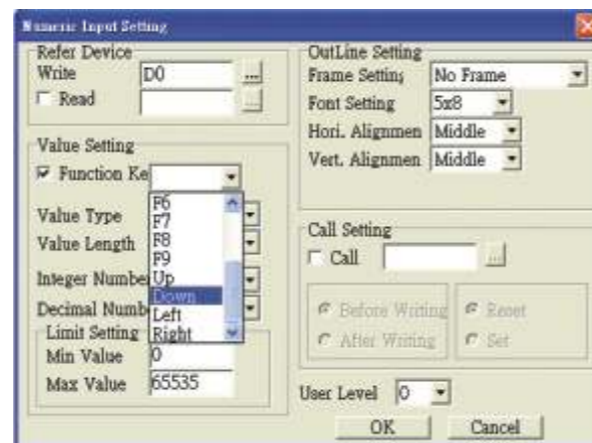

System Power On Macro

TPEditor has simple Marco command editing function. When TP series powers on, after a predefined time interval, Marco command will be executed automatically. This is very convenient for initial state setup.

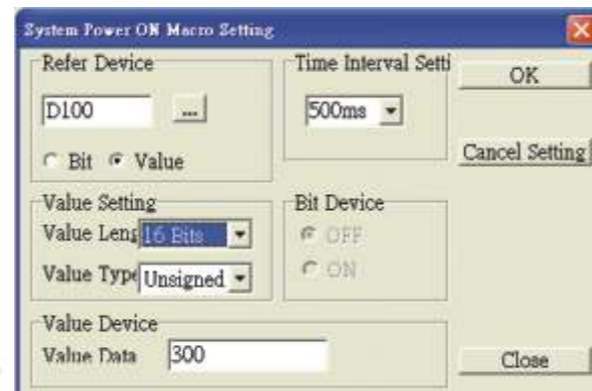

MODEL		AS38BSTD(-W)	AS57BSTD	AS57CSTD
LCD MODULE	Display Type	3.8" STN LCD (8 Shades of Blue)	5.7" STN LCD (8 Shades of Blue)	5.7" STN LCD (256 colors)
	Resolution	320 x 240 pixels	320 x 240 pixels	320 x 240 pixels
	Back Light	LED Back Light (about 10 thousand hours at 25°C)	CCFL Back Light (about 50 thousand hours at 25°C)	
	Display Size	3.8" (76.8 x 57.6mm)	5.7" (115.17 x 86.37mm)	
Operation System		Windows Base Real Time OS		
MCU		32-bit RISC Micro-controller		
NOR Flash ROM		NOR Flash ROM 2 Mbytes (System: 1MB / User: 1MB)		
SDRAM		4 Mbytes	16Mbytes	
Backup Memory (Bytes)		128K		
EXT. Memory	SM Card			
	USB Host (Ver 1.1)	✓	✓	✓
Extension Interface				
USB for Download [USB Client]		1 USB Client Ver 1.1		
USB for Data Storage / Printer [USB Host]		✓	✓	✓
Serial COM Port	COM1	RS-232	RS-232	RS-232
	COM2	RS-422/485	RS-422/485	RS-422/485
	COM3	RS-232	RS-422/485	RS-422/485
Function Key		User defined key x 4 + System key (SYS) x 1		
Operation Voltage		DC +24V (-10% ~ +15%) (Please use isolated power supply) ^(Note 2)		
Backup Battery		3V lithium battery CR2032 x 1 / battery life: 5 years		
Buzzer		85dB		
Perpetual Calendar (RTC)		Built-in		
Cooling Method		Natural Air Circulation		
Safety Approval (Waterproof for front panel)		IP65 / NEMA4 / CE, UL ^(Note 1)		
Operating Temp.		0°C to 50°C		
Storage Temp.		-20°C to +60°C		
Ambient Humidity		10% ~ 90% RH [0~40°C] · 10% ~ 55% RH [41~50°C] · Pollution Degree 2		
Vibration Resistance		IEC 61131-2 Compliant 5Hz ≤ f < 9Hz = Continuous: 1.75mm / Occasional: 3.5mm 9Hz ≤ f ≤ 150Hz = Continuous: 0.5g / Occasional: 1.0g X, Y, Z directions for 10 times		
Dimensions (W) x (H) x (D) mm		140.8 x 104.8 x 44.8	184.1 x 144.1 x 47.8	
Panel Cutout (W) x (H) mm		118.8 x 92.8	172.4 x 132.4	
Weight		Approx. 310g	Approx. 760g	

1) Only DOP-AE94BSTD is not UL recognized. The application is in progress.
 2) Users please use isolated power supply except DOP-A80THD1, DOP-AE80THD, DOP-AE94BSTD, and DOP-A(E)10THD1 these models.
 3) Users can download the Screen Editor, the program editor of Delta HMI product and the user manual via the following link: <http://www.delta.com.tw/industrialautomation/>.

HMI Specifications

MODEL		A(E)57BSTD(-W)	A(E)57GSTD(-W)	A(E)57CSTD(-W)
LCD MODULE	Display Type	5.7" STN LCD(8 Shades of Blue)	5.7" FSTN LCD (16 Shades of Gray)	5.7" STN LCD (256 colors)
	Resolution	320 x 240 pixels	320 x 240 pixels	320 x 240 pixels
	Back Light	CCFL Back Light (about 50 thousand hours at 25°C)		
	Display Size	5.7" (115.17 x 86.37mm)	5.7" (115.17 x 86.37mm)	5.7" (115.17 x 86.37mm)
Operation System		Windows Base Real Time OS		
MCU		32-bit RISC Micro-controller		
NOR Flash ROM		NOR Flash ROM 4 Mbytes (System: 1MB / User: 3MB)		
SDRAM		16 Mbytes		
Backup Memory (Bytes)		A:256K AE:512K	A:256K AE:512K	A:256K AE:512K
EXT. Memory	SM Card	✓	✓	✓
	USB Host (Ver 1.1)			
Extension Interface		✓ (AE)	✓ (AE)	✓ (AE)
USB for Download [USB Client]		1 USB Client Ver 1.1		
USB for Data Storage / Printer [USB Host]				
Serial COM Port	COM1	RS-232	RS-232	RS-232
	COM2	RS-232/422/485	RS-232/422/485	RS-232/422/485
	COM3	RS-232/422/485	RS-232/422/485	RS-232/422/485
Function Key		User defined key x 4 + System key (SYS) x 1		
Operation Voltage		DC +24V (-10% ~ +15%) (Please use isolated power supply) ^(Note 2)		
Backup Battery		3V lithium battery CR2032 x 1 / battery life: 5 years		
Buzzer		85dB		
Perpetual Calendar (RTC)		Built-in		
Cooling Method		Natural Air Circulation		
Safety Approval (Waterproof for front panel)		IP65 / NEMA4 / CE, UL ^(Note 1)		
Operating Temp.		0°C to 50°C		
Storage Temp.		-20°C to +60°C		
Ambient Humidity		10% ~ 90% RH [0~40°C] · 10% ~ 55% RH [41~50°C] · Pollution Degree 2		
Vibration Resistance		IEC 61131-2 Compliant 5Hz ≤ f < 9Hz = Continuous: 1.75mm / Occasional: 3.5mm 9Hz ≤ f ≤ 150Hz = Continuous: 0.5g / Occasional: 1.0g X, Y, Z directions for 10 times		
Dimensions (W) x (H) x (D) mm		184.1 x 144.1 x 47		
Panel Cutout (W) x (H) mm		172.4 x 132.4		
Weight		Approx. 760g		

MODEL		A80THTD1 / AE80THTD	AE94BSTD	A(E)10THTD1
LCD MODULE	Display Type	8" TFT LCD (65536 colors)	9.4" STN LCD(8 Shades of Blue)	10.4" TFT LCD (65536 colors)
	Resolution	640 x 480 pixels	640 x 480 pixels	640 x 480 pixels
	Back Light	CCFL Back Light (about 50 thousand hours at 25°C)	CCFL Back Light (about 30 thousand hours at 25°C)	CCFL Back Light (about 30 thousand hours at 25°C)
	Display Size	8" (162.2 x 121.7mm)	9.4" (192.0 x 144.0mm)	10.4" (211.2 x 158.4mm)
Operation System		Windows Base Real Time OS		
MCU		32-bit RISC Micro-controller		
NOR Flash ROM		NOR Flash ROM 8 Mbytes (System: 1MB / User: 7MB)		
SDRAM		32 Mbytes	16 Mbytes	32 Mbytes
Backup Memory (Bytes)		512K	512K	A:256K AE:512K
EXT. Memory	SM Card	✓ (AE)		
	USB Host (Ver 1.1)	✓	✓	✓
Extension Interface		✓ (AE)	✓	✓ (AE)
USB for Download [USB Client]		1 USB Client Ver 1.1		
USB for Data Storage / Printer [USB Host]		✓	✓	✓
Serial COM Port	COM1	RS-232	RS-232	RS-232
	COM2	RS-232/422/485	RS-232/422/485	RS-232/422/485
	COM3	RS-232/422/485	RS-232/422/485	RS-232/422/485
Function Key		User defined key x 6 + System key (SYS) x 1	User defined key x 11 + System key (SYS) x 1	User defined key x 7 + System key (SYS) x 1
Operation Voltage		DC +24V (-10% ~ +15%) (Please use isolated power supply) ^(Note 3)		
Backup Battery		3V lithium battery CR2032 x 1 / battery life: 5 years		
Buzzer		85dB		
Perpetual Calendar (RTC)		Built-in		
Cooling Method		Natural Air Circulation		
Safety Approval (Waterproof for front panel)		IP65 / NEMA4 / CE, UL ^(Note 1)		
Operating Temp.		0°C to 50°C		
Storage Temp.		-20°C to +60°C		
Ambient Humidity		10% ~ 90% RH [0~40°C] · 10% ~ 55% RH [41~50°C] · Pollution Degree 2		
Vibration Resistance		IEC 61131-2 Compliant 5Hz ≤ f < 9Hz = Continuous: 1.75mm / Occasional: 3.5mm 9Hz ≤ f ≤ 150Hz = Continuous: 0.5g / Occasional: 1.0g X, Y, Z directions for 10 times		
Dimensions (W) x (H) x (D) mm		243.1 x 178.1 x 52.4	297.1 x 222.1 x 51.1	297.1 x 222.1 x 51.1
Panel Cutout (W) x (H) mm		231.4 x 166.4	285.2 x 210.2	285.2 x 210.2
Weight		Approx. 1140g	Approx. 1700g	Approx. 1735g

1) Only DOP-AE94BSTD is not UL recognized. The application is in progress.
 2) Users please use isolated power supply except DOP-A80THTD1, DOP-AE80THTD, DOP-AE94BSTD, and DOP-A(E)10THTD1 these models.
 3) Users can download the Screen Editor, the program editor of Delta HMI product and the user manual via the following link: <http://www.delta.com.tw/industrialautomation/>.

1) Only DOP-AE94BSTD is not UL recognized. The application is in progress.
 2) Users please use isolated power supply except DOP-A80THTD1, DOP-AE80THTD, DOP-AE94BSTD, and DOP-A(E)10THTD1 these models.
 3) Users can download the Screen Editor, the program editor of Delta HMI product and the user manual via the following link: <http://www.delta.com.tw/industrialautomation/>.

TP Specifications

Dimensions

MODEL		TP02G-AS1	TP04G-AS2	TP05G-BT2	TP08G-BT2
LCD MODULE	Display Type	STN LCD			
	Display Color	Monochrome			
	Resolution	160 x 32	128 x 64	160 x 80	240 x 128
	Back Light	about 50 thousand hours at 25°C			
	Display Size	72 x 22mm	3"(67 x 32mm)	3.6" (83 x 41mm)	
Flash Memory		256K Byte		1M Byte	
Program Download Port		COM1(RS-232)			
Serial COM Port	COM1	RS-232	RS-232/422		
	COM2	RS-485			
Extension Interface		Program Copy Card			
Perpetual Calendar (RTC)		N/A	Built-in		
Function Key	System Key	6	7	12	
	Function Key	10	5	12	
Operation Voltage		DC +24V (-10% ~+20%)			
Backup Battery		3V lithium battery CR2032 x 1 / battery life: 5 years			
Buzzer		85dB			
Cooling Method		Natural Air Circulation			
Operating Temp.		0°C to 50°C			
Storage Temp.		-20°C to +60°C			
Ambient Humidity		10% ~ 90% RH [0~40°C]			
Vibration Resistance		IEC 61131-2 Compliant 5Hz ≤ f < 9Hz = Continuous: 1.75mm / Occasional: 3.5mm 9Hz ≤ f ≤ 150Hz = Continuous: 0.5g / Occasional: 1.0g X, Y, Z directions for 10 times			
Dimensions (W) x (H) x (D) mm		147 x 97 x 35.5		210 x 122 x 45	
Panel Cutout (W) x (H) mm		136 x 85		196 x 108	
Weight		240g		430g	
Safety Approval (Waterproof for front panel)		IP65/NEMA4 & CE, UL Type 4 indoor			

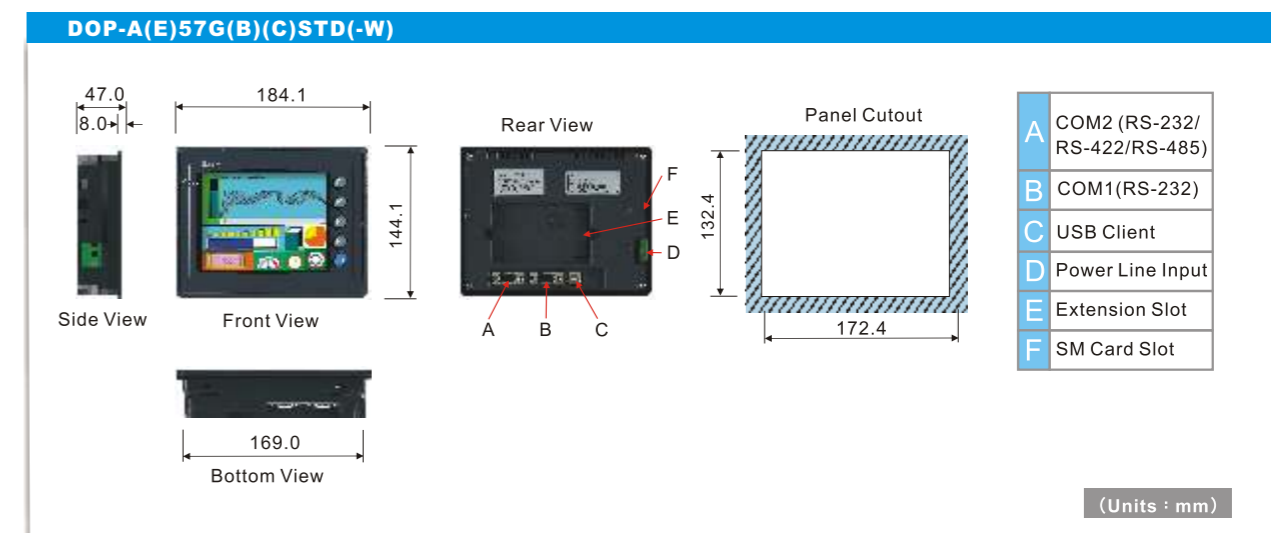
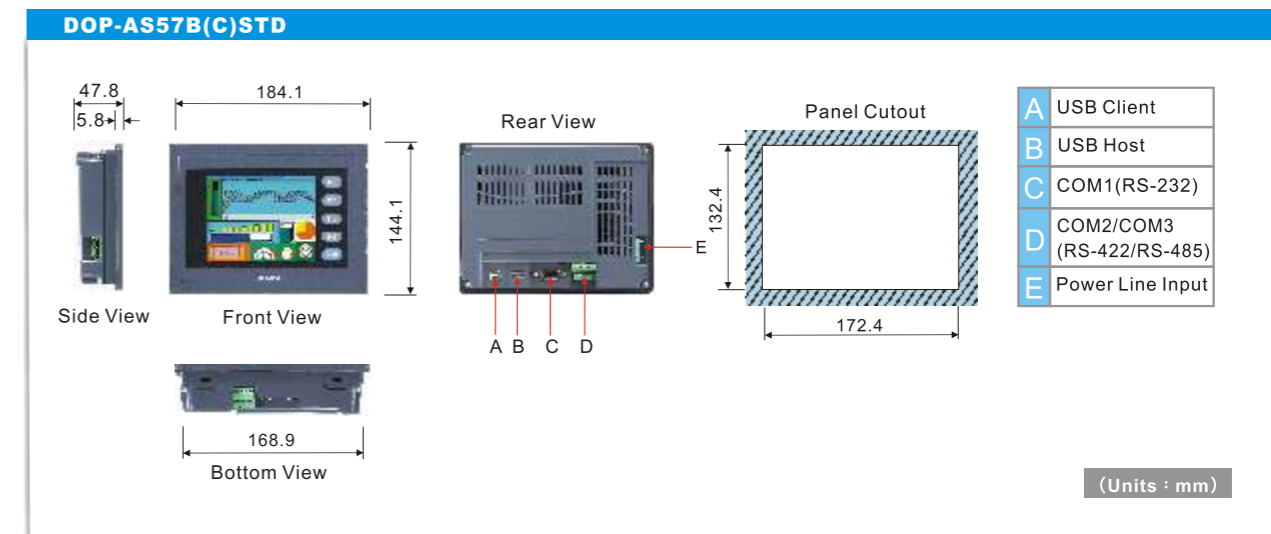
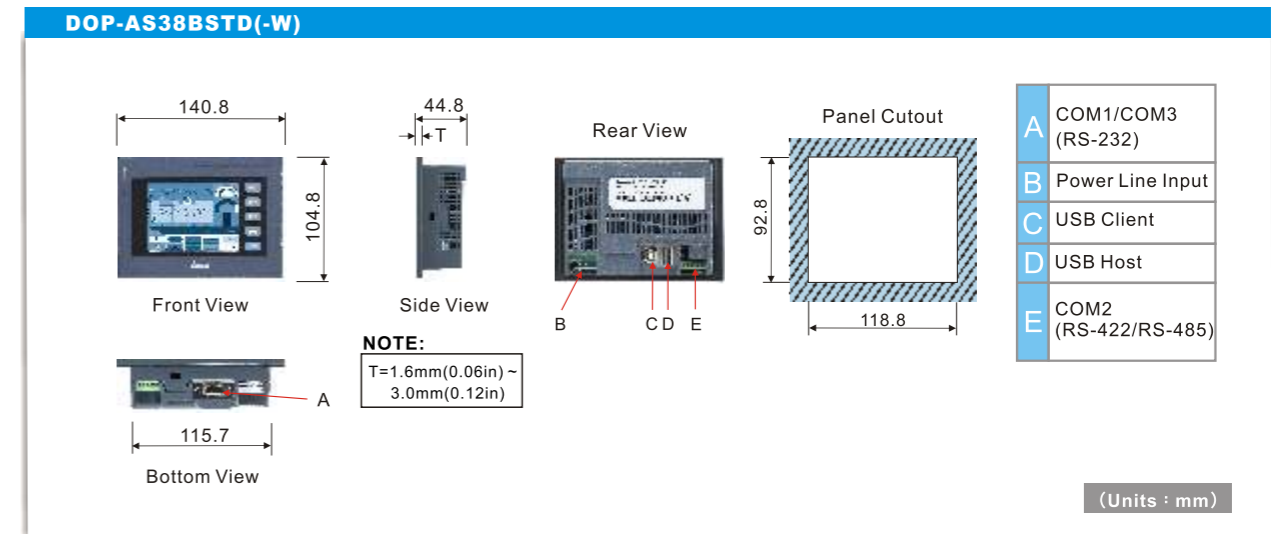

Dimensions

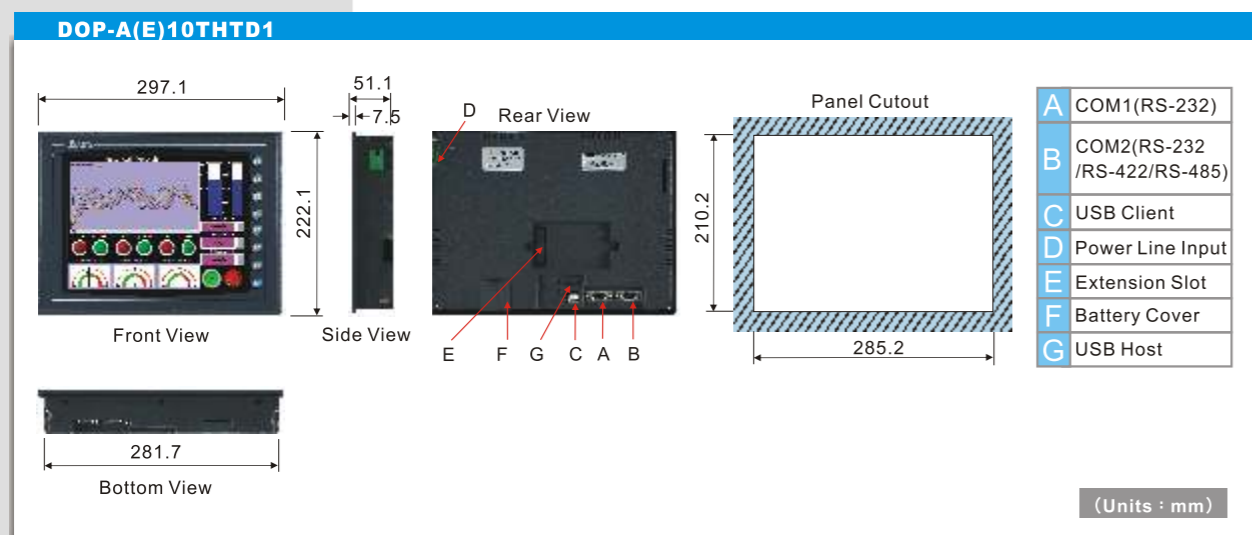
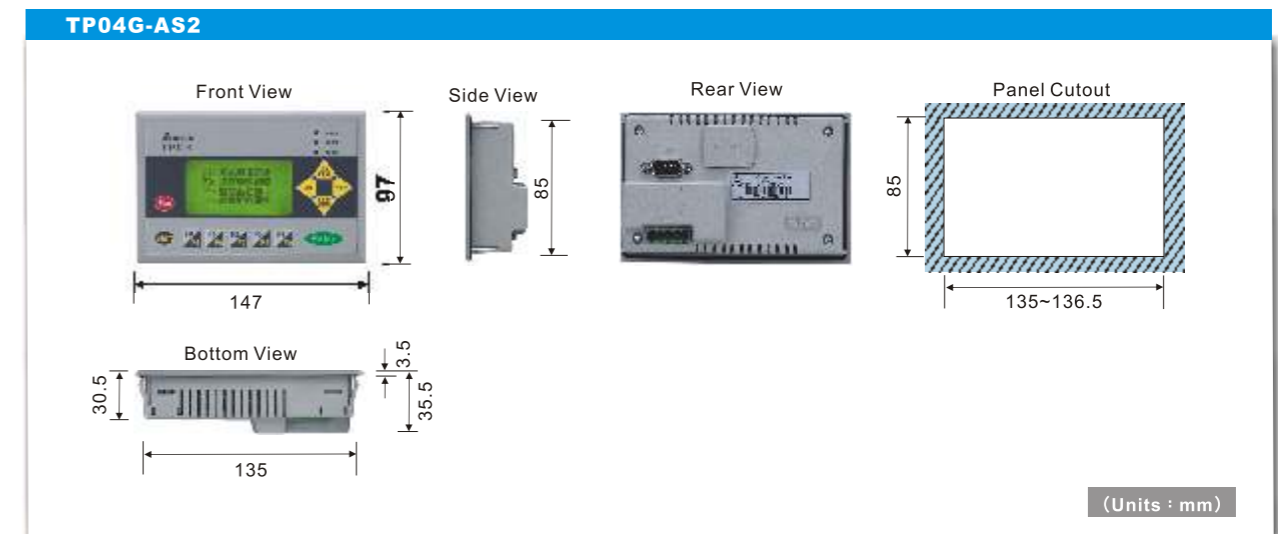
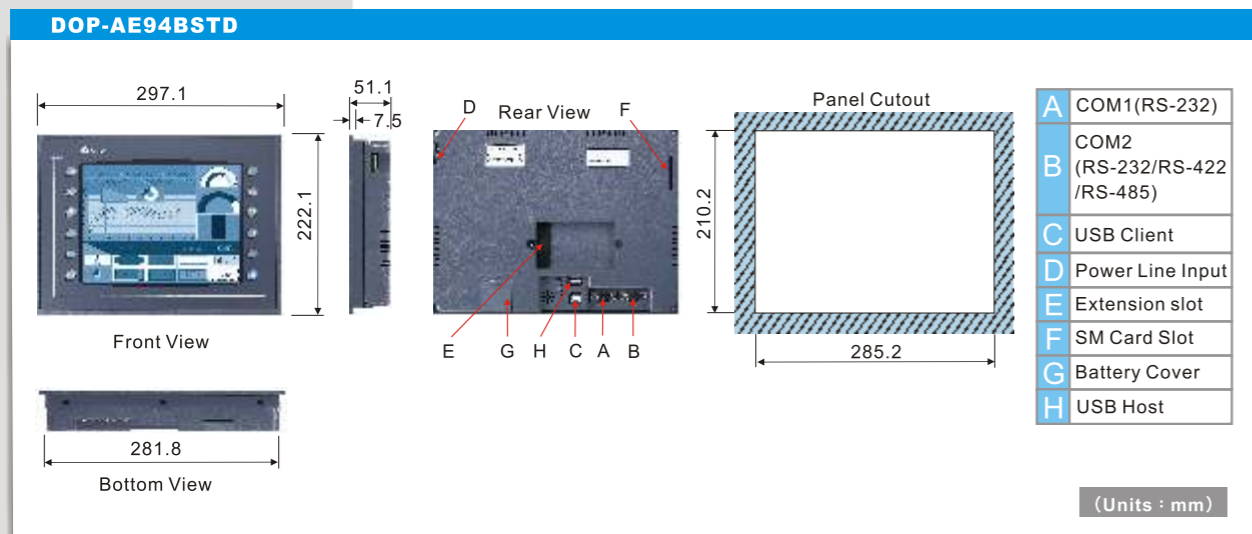
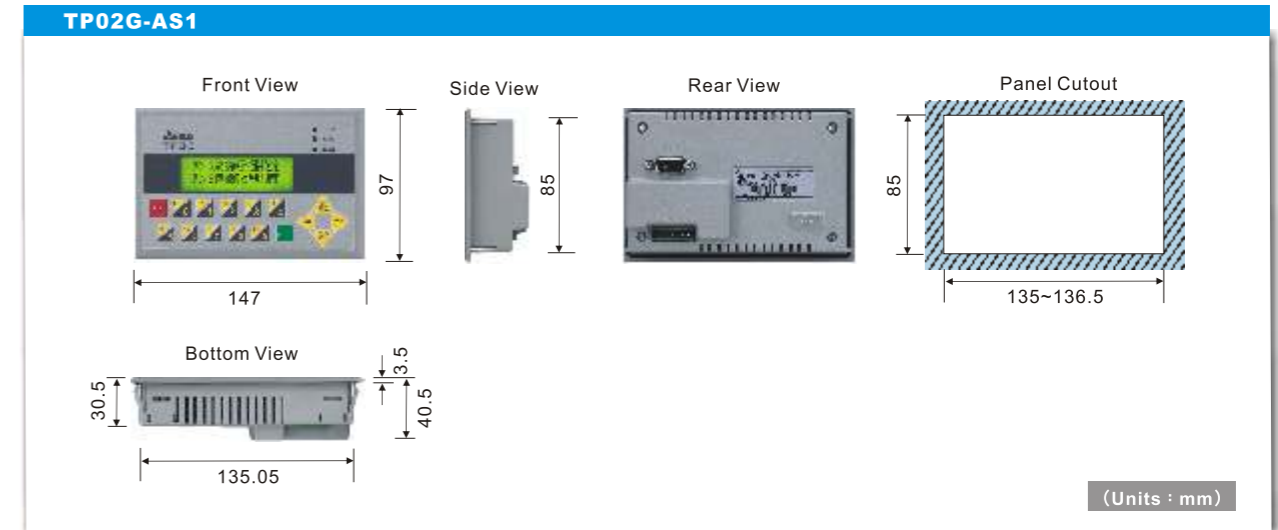
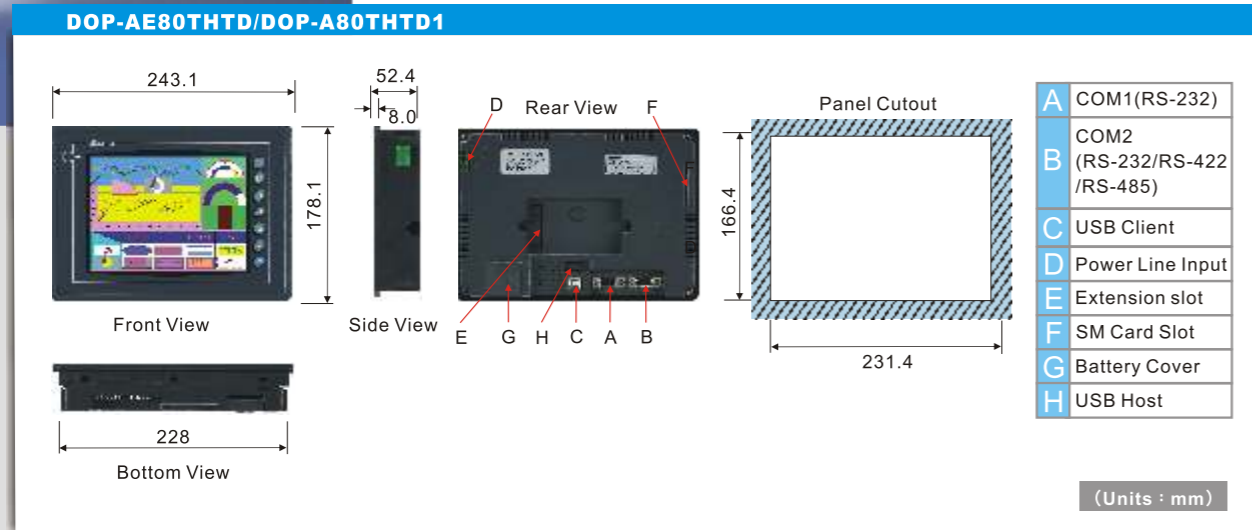

Extension Module Specifications

Extension Digital DIO Module

Electric Specifications

Item / Model Name	DOP-EXIO14RAE	DOP-EXIO28RAE
Power Supply Voltage	5VDC, 1A (supplied by HMI)	
Ambient Temperature / Humidity	Operation: 0°C ~ 50°C (Temperature), 10 ~ 90% (Humidity) Storage: -40°C ~ 85°C (Temperature), 10 ~ 90% (Humidity)	

Input Point Electric Specifications

Item / Model Name	DOP-EXIO14RAE	DOP-EXIO28RAE
Input Type	DC (SINK or SOURCE)	
Response Time	24VDC (5mA)	
Input Current	Approx. 10ms	
Active Level	OFF->ON	above 16VDC
	ON->OFF	below 14.4VDC

Output Point Electric Specifications

Item / Model Name	DOP-EXIO14RAE	DOP-EXIO28RAE
Output Type	Relay-R	
Maximum Working Exchange Frequency	Load ON/OFF Control	
Current Specifications	1.5A/1 Point(5A/COM)	
Voltage Specifications	250VAC, below 30VDC	
Response Time	Approx. 10ms	



DOP-EXIO14RAE • DOP-EXIO28RAE

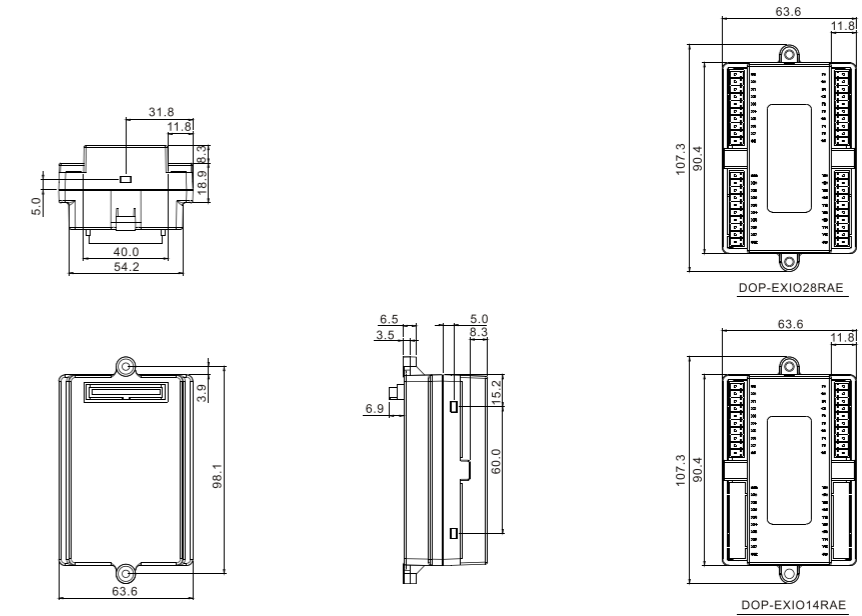

Extension Ethernet Module

Item / Model Name	DOP-EXLNHJ1AE
Power Supply Voltage	DC 5V, 1A(supplied by HMI)
Ambient Temperature / Humidity	Operation: 0°C ~ 50°C (Temperature), 10 ~ 90% (Humidity) Storage: -40°C ~ 85°C (Temperature), 10 ~ 90% (Humidity)
Interface	10Base-T, 100Base-TX



DOP-EXINHJ1AE

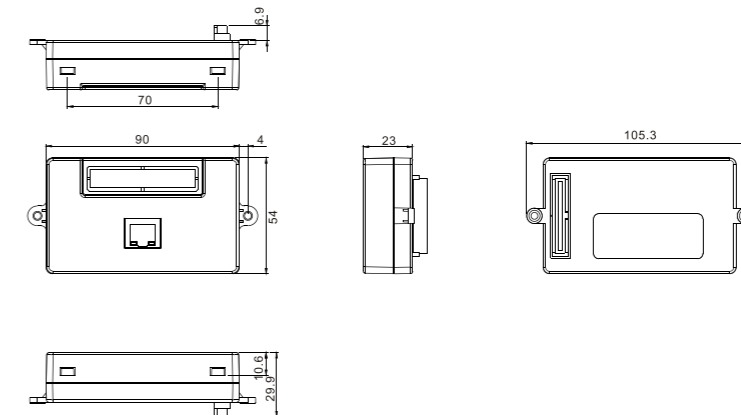

Extension Printer Module

Item / Model Name	DOP-EXPM110
Power Supply Voltage	DC 5V, 1A(supplied by HMI)
Ambient Temperature / Humidity	Operation: 0°C ~ 50°C (Temperature), 10 ~ 90% (Humidity) Storage: -40°C ~ 85°C (Temperature), 10 ~ 90% (Humidity)
Interface	25-pin Parallel Printer Port



DOP-EXPM110

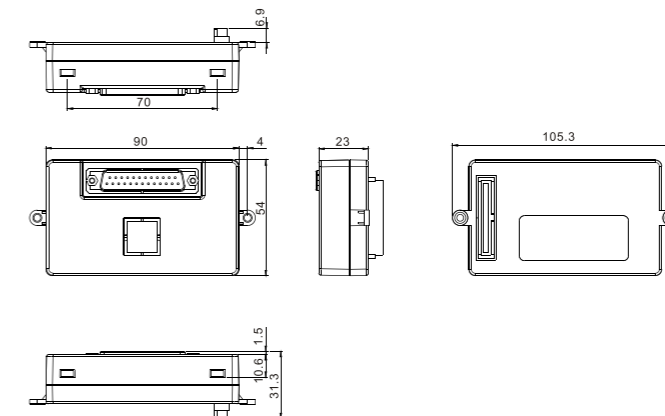

*Extension Digital I/O, Ethernet and Printer Modules are available for DOP-AE series HMI only.

Dimensions

DOP - A 80 TH T D 1 -W
 (1) (2) (3) (4) (5) (6) (7) (8)

(1)Product Name	DOP: Delta Operation Panel
(2)Series	AS: Delta AS series HMI A: Delta A series HMI AE: Delta AE series HMI
(3)Display Size	38: 3.8 inches 57: 5.7 inches 80: 8 inches 94: 9.4 inches 10: 10.4 inches
(4)Display Type	BS : 8 Shades of Blue, STN monochrome LCD GS : 16 Shades of Gray, FSTN monochrome LCD CS : 256 colors, STN color LCD TC : 256 colors, TFT color LCD TH : 65536 colors, TFT color LCD
(5)Control Interface	T: Touch Panel
(6)Rated Voltage	D: DC+24V
(7)Version Identification Code	
(8)Case Color	None : Gray W : White ^(Note1)
Note1 : Only the following models are provided with white case: A(E)57BSTD, A(E)57CSTD, A(E)57GSTD, AS38BSTD	

TP 02 G - AS 1
 (1) (2) (3) (4) (5)

(1) Product Name	TP: Terminal Panel
(2) Display Line Number	02 : 2 lines displaying model 04 : 4 lines displaying model 05 : 5 lines displaying model 08 : 8 lines displaying model
(3) Display Type	G : Graphic mode
(4) Version	AS: Without numeric keypad BT: With numeric keypad
(5) COM Port	1 : COM1 is for RS-232 2 : COM1 can be either RS-232 or RS-422

DOP-CA232DP	HMI-PLC RS-232 Cable	
DOP-CAUSBAB	HMI USB Cable	
DOP-EXIO14RAE	14 Points (8 IN / 6 OUT) Extension Digital I/O Module	
DOP-EXIO28RAE	28Points (16 IN / 12 OUT) Extension Digital I/O Module	
DOP-EXLNHJ1AE	Extension Ethernet Module	
DOP-EXPM110	Extension Printer Module	